

Whole House Filtration System Installation Guide



HOME
FILTRATION SYSTEMS

PURE WATER SOLUTIONS

Contents

Installation and Operation Manual	1
Guidelines and Warnings	2
Installation	4 - 5
Install Pre-Filtration System	7
Typical Installation	8
Installation Examples	9
Cartridge Installation and Replacement	10 - 11
Replacement Guide	12 - 13
Warranty	14 - 15









Installation and Operation Manual

We are delighted that you have chosen to invest in a Home Filtration Systems Whole House Water Filtration System. Our system is crafted with exceptional quality stainless steel and marine grade aluminium components, ensuring that you will enjoy pure, fresh water free from impurities for years to come with proper maintenance.

It is important to note that the system should not be used with water that is microbiologically unsafe or of unknown quality without appropriate disinfection. While our system is primarily designed for mains water supply (SYS-203-WAWF), it is versatile and can be adapted for other water sources. Should you require assistance with different types of water supply, please reach out to your local Home Filtration Systems 0474 189 347. To maintain peak performance, the filter cartridges within the system must be replaced within every 12 months. This process is straightforward when following the provided instructions. For guidance on cartridge replacements, please contact your nearest Home Filtration Systems stockist. Thank you for choosing Home Filtration Systems for your water filtration needs.

Guidelines and Warnings

Your safety is our priority, and following these guidelines will help maximise the performance and longevity of your water filtration system. If you have any questions or concerns, please do not hesitate to contact us for further assistance.

-  If the line pressure exceeds 520 kPa (75 psi), it is essential to install a pressure limiting valve to prevent damage to the system's housing. Take precautions to protect the housing from water hammer impacts.
-  The system is designed for use with cold water lines only, with water temperatures up to 52°C. If installation site requirements exceed 52°C, please consult with us regarding a suitable housing. To prevent damage, ensure the system is protected from freezing temperatures and avoid direct sunlight exposure during installation.
-  Use PTFE thread seal tape on all connections to ensure a secure and leak-proof fit. The use of pipe or thread sealants is not recommended, as it may void the warranty. Avoid overtightening connections, as this can risk splitting the housing.
-  For point of entry installations, an approved dual check backflow prevention device must be installed in compliance with national plumbing product codes. This safeguard is essential for maintaining water quality and preventing contamination.
-  Only use the system with water that is microbiologically safe and of known quality. Adequate disinfection measures must be taken when using water from uncertain sources.
-  It is crucial that this product be installed in accordance with local plumbing regulations by a licensed plumber to ensure safety and compliance with industry standards.

Installation

As with any product, a water filter system or tap has a limited lifespan and may eventually fail. In some cases, unexpected circumstances may lead to premature failure. To prevent potential property damage, it is crucial to routinely inspect the product for signs of leakage or deterioration and replace it as needed. Furthermore, in applications where leakage could result in property damage, a drain pan plumbed to a suitable drainage system or equipped with a leak detector should be utilised. It is advisable to turn off the water supply if there is no one present at home to prevent any potential damage.

It is essential that installation is carried out by a licensed plumber. Any faulty operation resulting from the involvement of unqualified tradespeople will lead to voided warranty coverage. Your safety and satisfaction are of utmost importance to us, and adhering to these guidelines will help ensure the efficient and safe operation of your water filter system. Please do not hesitate to reach out if you have any queries or require further assistance.

Professional Installation Required

Professional installation is essential for the successful setup of your filtration system. The installation process involves shutting off the water supply to your home, cutting the main water supply pipe, and using a crimping tool to add necessary piping and fittings. This work requires specialised tools and expertise and should not be attempted as a DIY project.

Positioning Your Filtration System

When selecting a location for your filtration system, ensure that any water spillage will not result in damage to surrounding areas. It is vital to choose a mounting position that is secure, ensuring the filter housing remains in place when changing filters. Consider installing an isolation valve just before the filter to enable easy isolation of the filter when replacing the cartridge. This valve will facilitate seamless maintenance of your filtration system while minimising disruptions to your water supply.

Installation (Continued)

For optimal performance and longevity of your filtration system, it is crucial to follow these installation guidelines and seek the assistance of a qualified professional. Please reach out if you have any inquiries or require further information.

System Dimensions



HFS is a proud sponsor of APOD.



Install Pre-Filtration System

1. Begin by isolating the water supply and relieving pressure by opening a downstream tap to ensure a safe working environment.
2. Cut the pipe to the required length for the valve and housing installation, ensuring a precise fit for optimum performance.
3. Utilise approved brass, galvanised, or poly plumbing fittings that are compatible with the existing pipework. The female threads on the housing are designed to receive tapered male threads. Carefully thread the fittings into the housing head, avoiding excessive tape or over-tightening, as this may lead to splitting. It is crucial to use PTFE thread seal tape on all connections to prevent leaks. Use of pipe or thread sealants will void the warranty.
4. If utilising sweated fittings, allow sufficient time for the fittings to cool before connecting them to the housing to prevent damage.
5. Install the wall mount bracket or frame securely, along with the pipework, using suitable clips for stability. Ensure there is at least 150mm clearance on the sides and below the system to facilitate maintenance and servicing.
6. Flush any debris from the pipework to maintain optimal functionality and prevent blockages.
7. Follow the instructions provided in the cartridge replacement guide (pg.7) to install the filter cartridge correctly, ensuring that it is securely in place for efficient filtration.
8. Adhering to these installation steps will help guarantee the effective operation and longevity of your pre-filtration system. If you encounter any difficulties or have further questions, please do not hesitate to seek assistance.

Cartridge Installation & Replacement

Use the QR code below to watch a video on how to replace the cartridges, or visit: [YouTube](#).



Typical Installation

1. Bypass (Not included)
2. Equal Tee (Not included)
3. Equal Tee (Not included)
4. Isolation valve (Not included)
5. Isolation valve (Not included)
6. Back Flow/Pressure Limiting Value (Not included)
7. 90 Degree Elbow (Not included)
8. 90 Degree Elbow (Not included)

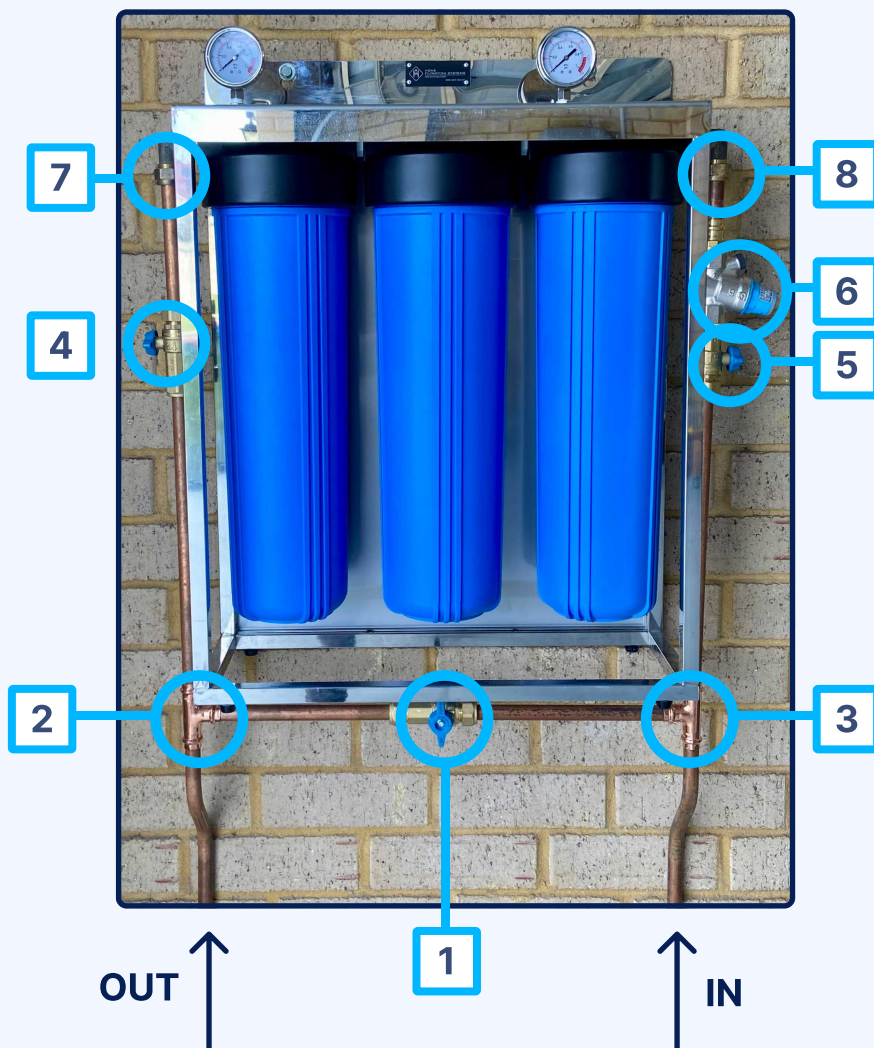

Installation Examples:

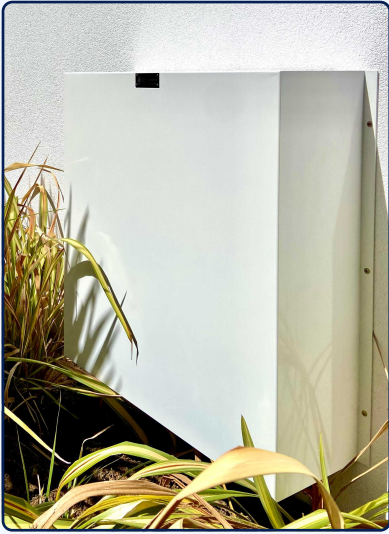

Cartridge Installation & Replacement

To change the filter cartridge(s) on your system, please follow these steps carefully:

1. Start by turning off the water supply and relieving pressure by opening a downstream tap or pressing the red pressure relief button on the housing (if available).
2. Unscrew the filter bowl(s). If you encounter difficulty, utilize the wrench provided to assist in removal. Remove the old cartridge(s). It is advisable to replace O-rings every 3 to 5 years to ensure a tight seal and prevent leaks.
3. Clean the bowl(s) using soap and warm water, then rinse thoroughly. Inspect the O-rings for any damage and replace them if necessary.
4. Check the lubrication of the O-rings; apply a light coating of food-grade silicone lubricant or a similar product if needed.
5. Unwrap the new filter cartridge(s) and carefully insert them into the housing bowl(s), ensuring that the cartridge(s) are correctly seated over the spigot in the base of the bowl(s). Remember to keep a record of the cartridge model number for future reference.
6. When screwing the bowl(s) back onto the head, ensure that the spigot in the housing head(s) aligns centrally with the cartridge(s) to create a proper seal. Hand tighten the bowl until firm, taking care not to over-tighten.
7. Open the downstream tap to release air and gradually turn on the water supply to purge all air from the system.

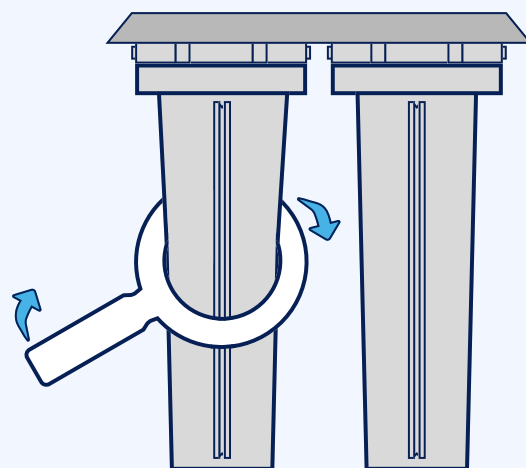
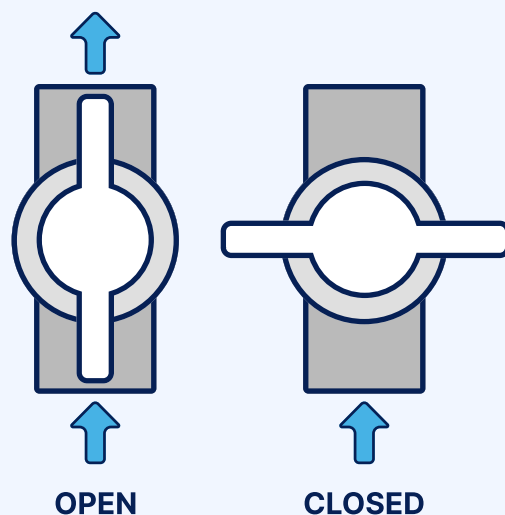

Cartridge Installation & Replacement (Continued)

8. Allow the water to run for 2 minutes to flush the system and ensure the new cartridge is properly installed.
9. Close the downstream tap and check for any signs of leaks. If the system has been unused for more than 2 days, flush it for 10 minutes. For periods of non-use exceeding 2 weeks, it may be necessary to replace the cartridge to maintain optimal performance.

Following these steps will help ensure the efficient operation and longevity of your filter system. If you encounter any issues or have further questions, please seek assistance.

This section provides guidance on how to redirect unfiltered water to your house for specific purposes such as gardening or pool filling. To achieve this, follow these steps:

1. Locate the valves going in and out of the filter system, labeled as #3 (inlet valve) and #7 (outlet valve).
2. Close both the inlet (#3) and outlet (#7) valves to stop the flow of water through the filtration system.
3. Locate and open the bypass valve, labeled as #9, to allow water to bypass the filtration system and flow directly into your house for activities such as gardening or pool filling.
4. By following these steps, you can easily switch to unfiltered water usage when necessary, while ensuring that the filtration system remains bypassed for the intended purposes mentioned.

Cartridge Installation & Replacement

This note provides guidance on how to redirect unfiltered water to your house for specific purposes such as gardening or pool filling. To achieve this, follow these steps:

1. Locate the valves going in and out of the filter system, labeled as #3 (inlet valve) and #7 (outlet valve).
2. Close both the inlet (#3) and outlet (#7) valves to stop the flow of water through the filtration system.
3. Locate and open the bypass valve, labeled as #9, to allow water to bypass the filtration system and flow directly into your house for activities such as gardening or pool filling.
4. By following these steps, you can easily switch to unfiltered water usage when necessary, while ensuring that the filtration system remains bypassed for the intended purposes mentioned.



Replacement Guide

To uphold the superior quality of purified water, it is recommended to replace the cartridge(s) every 12-18 months. The frequency of replacement may vary based on water quality and usage patterns. Replacement cartridges can be acquired from your local Home Filtration Systems stockist. To ensure optimal performance and maintain warranty coverage, it is imperative to use genuine Home Filtration Systems replacement cartridges. By adhering to the recommended replacement schedule and using authentic replacement cartridges, you can uphold the efficiency and longevity of your filtration system, guaranteeing the continued delivery of clean and purified water for you and your household.

Mains Water System Layout:

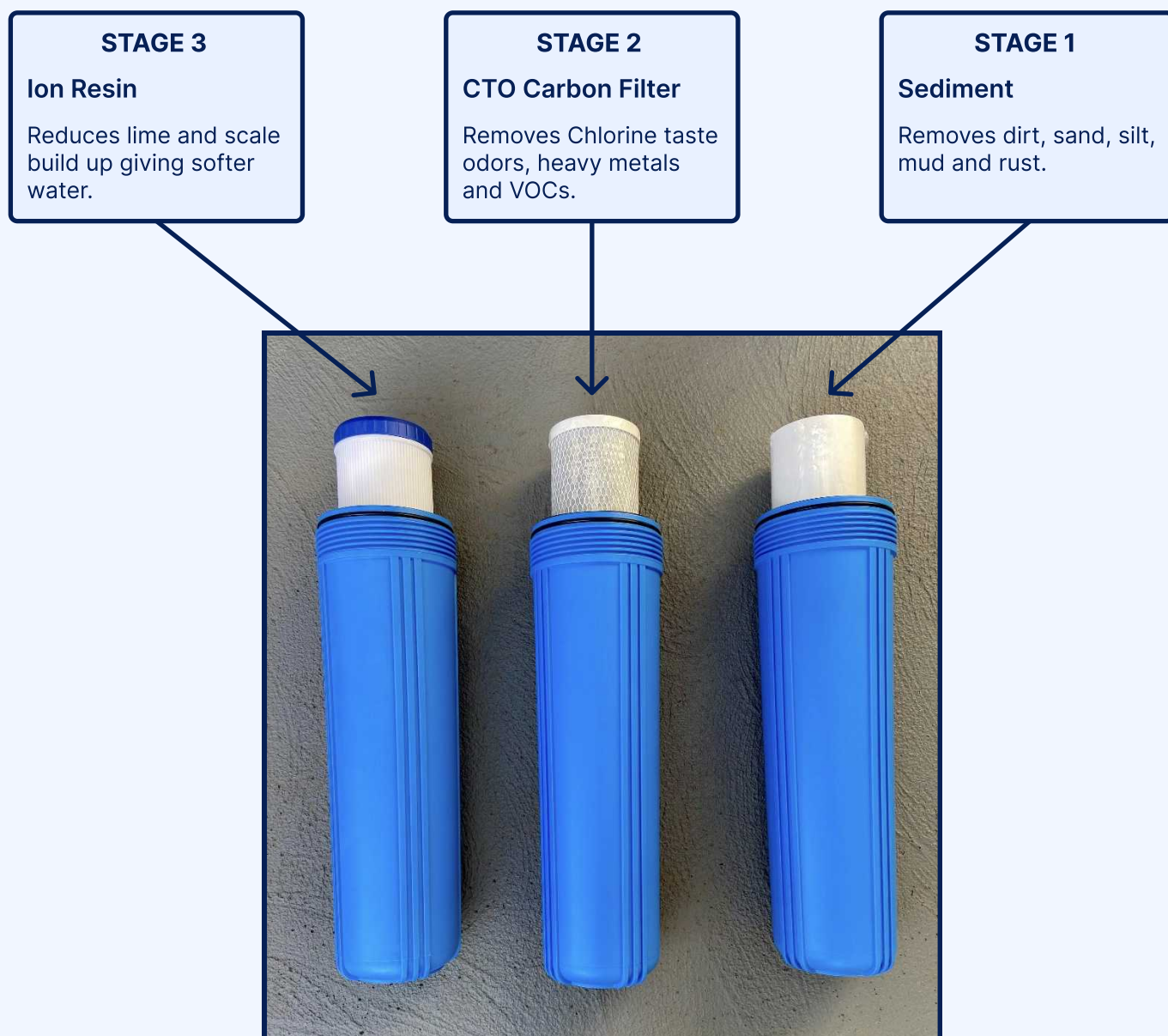

Replacement Guide (Continued)

Rainwater System Layout:

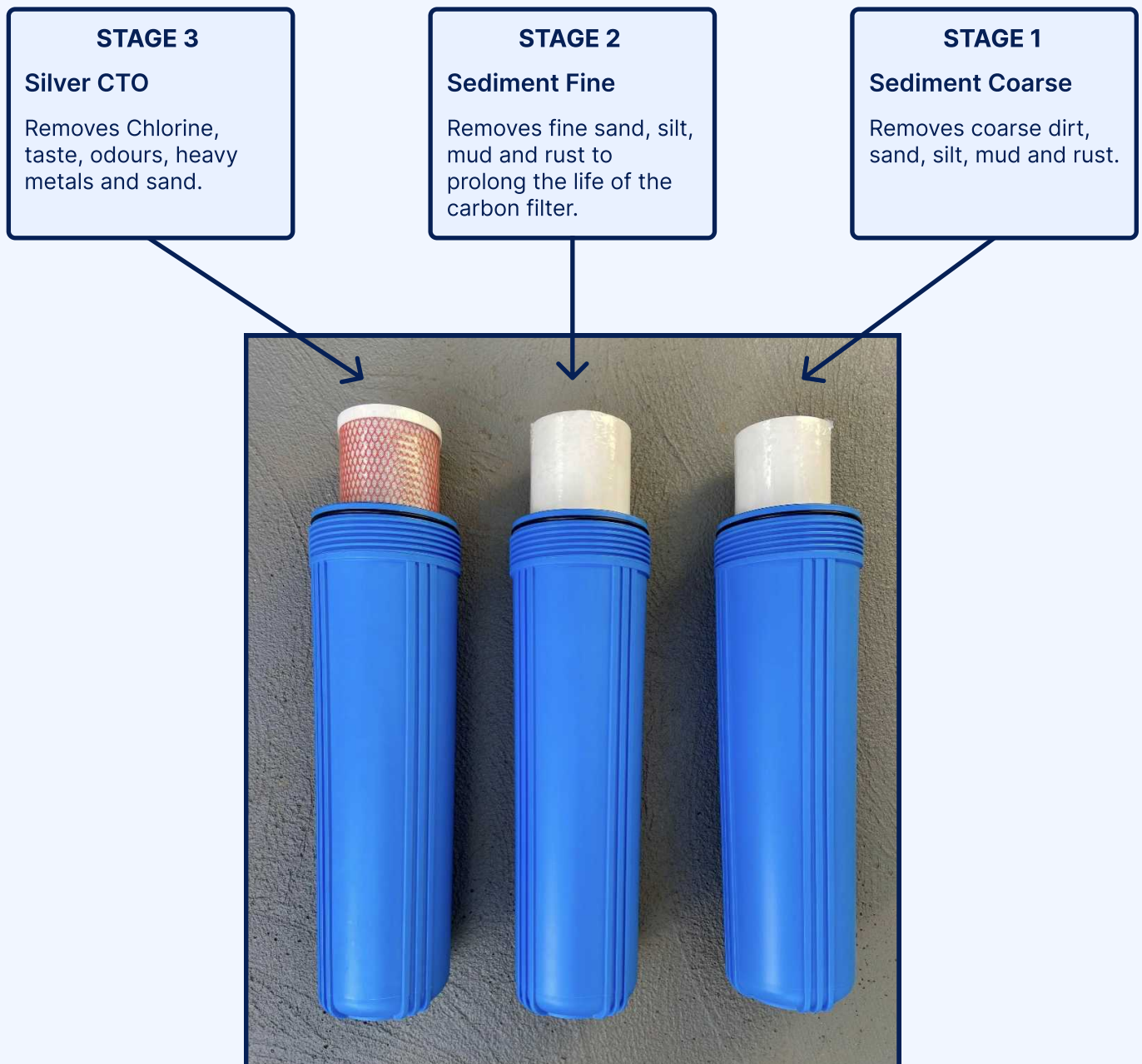





Warranty

Any contract of sale, order, or quotation made or accepted by Home Filtration Systems Pty Ltd is subject to these terms and conditions of sale.

- ◆ Home Filtration Systems Filters warrants Home Filtration Systems Filtration Systems to the original purchaser for a Lifetime warranty on the system excluding external fittings and pipes.
- ◆ Home Filtration Systems Filters reserves the right in instalment sales to grant credit for the value of any Product found to be defective under this Warranty.
- ◆ Home Filtration Systems Filters will not cover any labour charge incurred by the Buyer for the replacement or repair of any Product.
- ◆ The Buyer is responsible for freight and local labour charges for Products the subject of this Warranty
- ◆ This Warranty applies only to the original purchaser of the Product.
- ◆ Home Filtration Systems Filters' obligation under this Warranty is limited to Home Filtration Systems Filters' own option, to either repair or replace the
- ◆ It is crucial that this product be installed in accordance with local plumbing regulations by a licensed plumber to ensure safety and compliance with industry standards.
- ◆ Product, once Home Filtration Systems Filters has deemed that the Product is defective or Home Filtration Systems Filters may, at its own discretion, refund to the Buyer the purchase price paid for the defective goods.
- ◆ This Warranty does not cover any Product that is relocated from the site of its original installation.
- ◆ All replaced or exchanged parts taken out under this warranty become the property of Home Filtration Systems.
- ◆ This Warranty is subject to the Product being properly installed, maintained, being used for its intended purpose and operated strictly in accordance with Home Filtration Systems' recommendations and installation guide.



Warranty (Continued)

-  This Warranty does not extend to a Product that has been modified in any way unless with Home Filtration Systems' express consent.
-  This Warranty does not cover the normal wear and tear of the Product, or damage caused by misuse, abuse or vandalism.
-  The Warranty does not cover any malfunction or failure resulting from neglect, use of unauthorised parts and accessories or use with higher water pressure than indicated on the Product.
-  It is expressly agreed that this shall be the sole and exclusive remedy of the Buyer stated herein, and under no circumstances shall Home Filtration Systems be liable for any costs, loss, expense, damages, special damages, incidental damages or consequential damages arising directly or indirectly from the design, manufacture, sale, use or repair of the Product whether based upon warranty, contract, tort or strict liability.
-  All Conditions and Warranties implied by law or statute are hereby expressly negated so far as they lawfully can be.

Have Questions? Contact us.

Phone **0474 189 347**

Email **sales@homefiltrationsystems.com**

Website **homefiltrationsystems.com**



**HOME
FILTRATION SYSTEMS**

PURE WATER SOLUTIONS